

DESIGN AND FABRICATION OF CONICAL PIN FIN ARRAY

Jamal Uddin Ahamed^{1,*}, Md. Khaledur Rahman², M. A. Razzaq³, Md. Mahbubur Rahman⁴ and S. M. R. Iftakhar⁵

^{1, 2, 3, 5}Department of Mechanical Engineering, Chittagong University of Engineering & Technology, Chittagong, Bangladesh

⁴Department of Mechanical Engineering, Military Institute of Science and Technology, Dhaka, Bangladesh

^{1,*}jamal293@yahoo.com, ²khaled0903044@gmail.com, ³razzaqray@yahoo.com, ⁴mahbub.rizvee@gmail.com, ⁵rifatiftu@gmail.com

Abstract-The augmentation of convective heat transfer by using conical pin fins array has been investigated experimentally in the present work. Conical shape of aluminum fin having fin height (h) = 70 mm, base diameter (d) = 14.2 mm and fin spacing (s) = 45 mm of staggered arrangement has been selected for better performance. Seven pin fins have used in this experiment to investigate the heat transfer coefficient and fin efficiency. It has observed that for conical pin fin array the heat transfer coefficient increase with the increase of the temperature difference between wall and ambient in case of free convection. For free convection the efficiency of fin increase with the increase of the heat transfer coefficient. However for force convection it is observed that the efficiency of fin decrease with the increase of heat transfer coefficient and heat transfer rate has varied with the speed of fan and it has increased up to 16.49 %. It has also observed that efficiency of fin will decrease if velocity of fan increases in force convection. Finally a comparative study of pin fin efficiency of conical and cylindrical shape has been investigated. It has found that with the same power for conical and cylindrical pin fin arrays, conical array has 12.16 % higher efficiency and 1.77 % higher heat transfer coefficient.

Keywords: Convection, Free convection, Forced convection, Heat transfer coefficient, Fin efficiency

1. INTRODUCTION

Convection heat transfer between solid surface and the ambient fluid can be increased by increasing heat transfer area by attaching to the surface thin strips of metals called fins. The study of extended surface heat transfer in most cases comprises two factors that may conveniently be separated. One factor is only the movement of heat within the fin by convection other considers how the fin exchanges heat with the surroundings. The heat transfer can be increased by increasing the convection heat transfer coefficient or increasing the surface area of an object or increasing the temperature difference between the object and the environment. Adding a fin to an object, however, increases the surface area becomes an economical solution to heat transfer problems. Heat transferred through the fin can be take place by conduction, convection and radiation. Sometimes heat transferred by radiation is neglected. There have been many investigations restricted on the heat transfer and pressure drop in channels with pin-fins of circular cross-section [1-7]. Sparrow et al. [1] were among the first to investigate the heat transfer performance of inline and staggered wall attached arrays of cylindrical fins. Metzger et al. [3] investigated the heat transfer characteristics of staggered arrays of cylindrical pin-fins. Simoneau and Vanfossen [4] also studied the heat

transfer from a staggered array of cylindrical pin-fins. A review of staggered array pin-fin heat transfer for turbine cooling applications was presented by Armstrong and Winstanley [5]. The end wall heat transfer in the presence of inline and staggered adiabatic circular pin-fins were studied by Matsumoto et al. [6] The pin height-to-diameter ratios of typical heat sink used for such applications are between 1/2 and 4 [7]. Damerow et al. [8] measured pressure drops in channels with arrays of pin fins having H/D from 2 to 4 with various pin spacing geometries and found no H/D effect on the friction factor. A similar trend has been reported by Metzger et al. [9], who also obtained friction factors data, which agreed well with the long tube correlations proposed by Jacob [10]. Armstrong and Winstanley [11] compared the experimental data obtained by Peng [12], Metzger et al. [9], Damerow et al. [8], and Jacob [10]. The correlation proposed by Metzger et al. [9] provided the best fit for the data (within $\pm 15\%$), while Damerow's [8] correlation did not match the experimental results. Although Jacob's [10] correlation was originally developed for long fins, it predicted the experimental data fairly well. An interesting result that might explain the similar pressure drop trends for long and intermediate size tubes was obtained by Sparrow et al. [13]. Heat transfer and pressure drop of flow across tube bundles/pin fins have been a subject of extensive research over the last century

[14]. The Nusselt number and friction factor correlations obtained primarily through experimental studies have been developed for circular [15–19], rectangular [20, 21], oval [22], elliptical [23], diamond [24], hexagonal [25], and lenticular [26] configurations, among others. Dimensional analysis suggests that the convective heat transfer across long cylinders in cross flows varies with the Reynolds and Prandtl numbers. Flows over intermediate size pin fin banks have been commonly used in turbine cooling systems to increase the internal heat transfer characteristics. The pin height-to-diameter, H/d , ratios of typical heat sinks used for such applications were between 1/2 and 4 [27]. MizanurRahman (2007), BSc. Thesis paper, Chittagong University of Engineering and Technology (CUET) analyzed parabolic shape of fin [28]. Sanaullah Mohammad Yusuf (2007), BSc. Thesis paper, Chittagong University of Engineering and Technology (CUET) showed rectangular shape of fin more efficient than parabolic shape [29]. Pin fins are normally used because of their relative simplicity in fabrication. Therefore it is necessary to investigate different geometry of pin fins having different cross-section. So the aim of this study to investigate the heat transfer and performance characteristics for the conical pin-fin arrays attached on a flat surface in a rectangular box in case of free and force convection.

2. OBJECTIVES OF THE PROJECT

- To design and construction of pin fin array and set up in a flat plate wall.
- To determine the free and force convection heat transfer coefficient for an extended surface of varying cross section using pin shaped fin.
- To determine the performance of the conical pin fins.

3. EXPERIMENTAL METHOD

In this experiment conical pin fin is selected for heat transfer enhancement. The following parameters were selected during the experiment: Determination of fin size, Selection of the suitable types of fin material, Design the fin according to my project, Collection of the necessary raw material, Construction of fin array according to the size and shapes, Construction of a fin box shown in Fig. 1. After setting up a heater and a thermocouple in the fin box experimental data were taken by doing the experiment in several times. Finally calculate the efficiencies from the data.

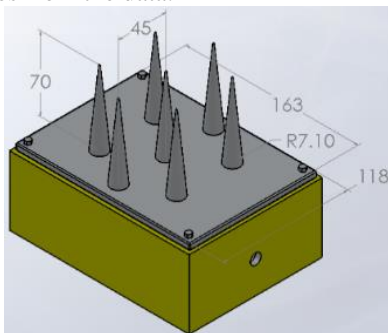

Fig.1: Pin fin array

3.1 Material Selection

Aluminum metal were selected for manufacturing fin array & plate box. For measuring voltage a Voltage regulator was used. Temperature was measured by using T-type thermocouple. For heating purpose heater was used. For insulation asbestos and heat insulating cloth were used. Multi-meter was used for measuring current through the heater. Fan was used for air supply and anemometer was used for measuring the velocity of the supply air.

3.2 Experimental Procedure

- Adequate time were allowed to reach steady state operation before noting the heated wall temperature (t_H).
- The air temperature and the temperature at each of three point along the fin (t_F) were measured.
- For the force convection switch on the fan and select a low speed whilst maintaining the input power constant.
- Reading rate were taken with the air velocity (U_A) after reaching steady state operation
- Number of data was taken for a range by increasing fan speed.

4. GOVERNING EQUATION

The rate of convection heat transfer from the extended surface

$$Q = hA_H(t_H - t_A) + hA_F(t_{FAV} - t_A)$$

where

h = convection heat transfer coefficient (assumed constant)

A_H = area of heated wall only

A_F = summed area of all fins

t_{FAV} = average temperature along the length of fins which may be approximated as mean temperature of three temperature measured along length.

Again, Total amount of heat supplied

$$Q = VI \cos\theta$$

where

V = Voltage supplied

I = Current

$\cos\theta$ = Power factor ≈ 0.8 (assume for this experiment)

The fin efficiency η is the ratio of the actual heat transfer from the surface to heat which would be transferred if the entire area were at base temperature. where

$$\eta = \frac{t_{FAV} - t_A}{t_H - t_A} \times 100$$

5. EXPERIMENTAL SETUP

During free convection (Fig. 2) supply power first passes through the voltage regulator from where we get supply voltage (Fig. 3). Then the supply power passes through the multi-meter for measuring supply current. After that it passes through the heater for heating purpose. The heated wall temperature was measured from thermocouple reading and this reading was used for measuring fin temperature. Data for free convection is shown in Table 1. But in case of forced convection (Fig. 4) an air duct was used for supplying adequate air. The

velocity of supply air was measured by using an anemometer. Data for forced convection by varying fan speed and power are shown in Table 2 & Table 3 respectively.

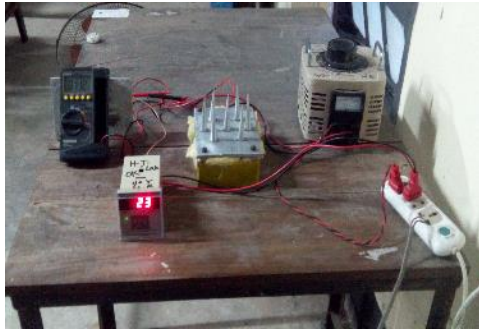

Fig 2: Assemble of fin for free convection

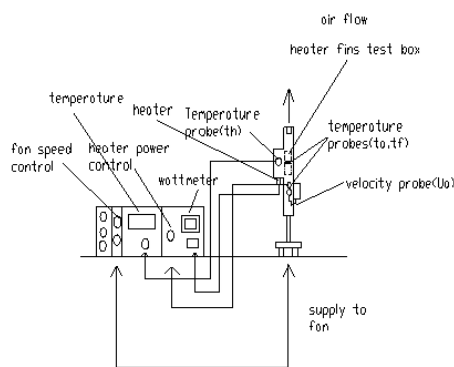

Fig. 3: Schematic diagram assemble of extended surface with electrical console.



Fig. 4: Assemble of fin for force convection.

Table 1: Data for free convection

Test No	V Volt	I Amp	Q Watts	t _H °C	t _A °C	t _{FAV} °C	t _H -t _A °C	t _{FAV} -t _A °C
1	80	0.56	35.84	67.75	25	50.67	42.75	25.67
2	100	0.66	52.8	86	25	64.33	61	39.33

3	120	0.78	74.88	97.25	25	72.66	72.25	47.66
---	-----	------	-------	-------	----	-------	-------	-------

Table 2: Data for force convection (varying speed)

Test No	v Volt	i Amp	Q Watts	t _H °C	t _A °C	t _F °C	t _H -t _A °C	t _{FAV} -t _A °C	U m/s
1	120	0.78	74.88	70	25	38	45	13	2.4
2	120	0.78	74.88	65	25	36	40	11	3.5
3	120	0.78	74.88	61	25	34	36	09	4.4

Table 3: Data for force convection (varying power)

Test No	v Volt	i Amp	Q Watts	t _H °C	t _A °C	t _F °C	t _H -t _A °C	t _{FAV} -t _A °C	U m/s
1	80	0.56	35.84	47	25	31	22	06	3.5
2	100	0.66	52.8	54	25	33	29	08	3.5
3	120	0.78	74.88	65	25	36	40	11	3.5

6. DATA ANALYSIS

- Determination of the heat transfer coefficient for free and force convection
- Determination of the fin efficiency

The convection heat transfer coefficient

$$h = \frac{Q}{A_H(t_H - t_A) + A_F(t_{FAV} - t_A)} \quad (6.1)$$

The fin efficiency = $\frac{\text{actual heat transfer from fin}}{\text{the maximum possible heat transfer from surface}}$

$$\eta = \frac{t_{FAV} - t_A}{t_H - t_A} \times 100 \quad (6.2)$$

If Pin diameter (d) = 14.2 mm, Pin length (L) = 70 mm, Plate length (A) = 170 mm, Plate width (B) = 120 mm, Plate thickness = 6 mm, Bolt dia (d_1) = 5 mm, No of bolts = 4, No of fins = 7

Area of heated wall $A_H = (\text{length} \times \text{width of plate}) - 4(\text{bolt cross section area}) - 7(\text{fin base area})$

$$= (A \times B) - 4\left(\frac{\pi}{4} \times d_1^2\right) - \left(\frac{\pi}{4} \times d^2\right) = .019213426 \text{ m}^2$$

$$\text{Summed area of fin } A_F = \pi d/2 [L^2 + (d/2)^2] \times 7 = .01099 \text{ m}^2$$

6.1 Wall Temperature Calculation

The plate material is contact with a heat source at an elevated temperature $t_1 = 98^\circ\text{C}$

The heated wall temperature = t_H

The thermal conductivity of aluminum $k = 202 \text{ W/m}^2\text{ }^\circ\text{C}$

Thickness of the plate $dx = .006 \text{ m}$

From Fourier's law of heat conduction

$$Q = k \frac{t_1 - t_H}{dx}$$

$$74.88 = 202 \frac{t_1 - t_H}{0.006}$$

$$t_1 - t_H = 0.002224158^\circ\text{C}$$

$$t_H = 98.002224158^\circ\text{C}$$

The temperature variation between the lower surface and upper surface = 0.00224158 which is very small (may be neglected).

6.2 Heat Transfer Coefficient & Efficiency Calculation

Free convection

For, power supply $Q = 35.84$ watts, Wall temperature $t_H = 67.75^\circ\text{C}$, ambient temperature $t_A = 25^\circ\text{C}$, $t_{FAV} = 50.67^\circ\text{C}$

The convective heat transfer coefficient from equation (6.1)

$$h = \frac{35.84}{.019213426 (67.75 - 25) + .01099 (50.67 - 25)}$$

$$= 32.5 \text{ W/m}^2\text{C}$$

The fin efficiency from equation (6.2)

$$\eta = \frac{50.67 - 25}{67.75 - 25} \times 100$$

$$= 60.0\%$$

Similarly for $Q = 52.8$ watts, $t_H = 86^\circ\text{C}$, $t_{FAV} = 64.33^\circ\text{C}$, $t_A = 25^\circ\text{C}$, $h = 32.9 \text{ W/m}^2\text{C}$, $\eta = 64.48\%$, and for $Q = 74.88$ watts, $t_H = 97.25^\circ\text{C}$, $t_{FAV} = 72.66^\circ\text{C}$, $t_A = 25^\circ\text{C}$, $h = 39.16 \text{ W/m}^2\text{C}$

$$\eta = 65.97\%$$

Force convection

For, power supply $Q = 74.88$ watts, Wall temperature $t_H = 70^\circ\text{C}$, ambient temperature $t_A = 25^\circ\text{C}$, $t_{FAV} = 38^\circ\text{C}$ and fan velocity $U = 2.4$ (m/s)

The convective heat transfer coefficient,

$$h = \frac{74.88}{.019213426 (70 - 25) + .01099 (38 - 25)}$$

$$= 74.32 \text{ W/m}^2\text{C}$$

The fin efficiency,

$$\eta = \frac{38 - 25}{70 - 25} \times 100$$

$$= 28.88\%$$

Similarly for $Q = 74.88$ watts, $t_H = 65^\circ\text{C}$, $t_{FAV} = 36^\circ\text{C}$, $t_A = 25^\circ\text{C}$ and velocity of air = 3.5 (m/s)

$$h = 84.19 \text{ W/m}^2\text{C}$$

$$\eta = 27.5\%$$

And for $Q = 74.88$ watts, $t_H = 61^\circ\text{C}$, $t_{FAV} = 34^\circ\text{C}$, $t_A = 25^\circ\text{C}$

$$h = 94.71 \text{ W/m}^2\text{C}$$

$$\eta = 25\%$$

7. RESULTS AND DISCUSSION

From Fig. 5, it is observed that the heat transfer coefficient increase with the increase of the temperature difference between wall and ambient for free convection. From Fig. 6, it is observed that the efficiency of fin increase with the increase of the heat transfer coefficient for free convection. By plotting the graph Fig 7, it is observed that the efficiency of fin decrease with the increase of heat transfer coefficient for forced convection. From Fig 8, it is observed that the heat transfer coefficient increases with the increase of fan velocity.

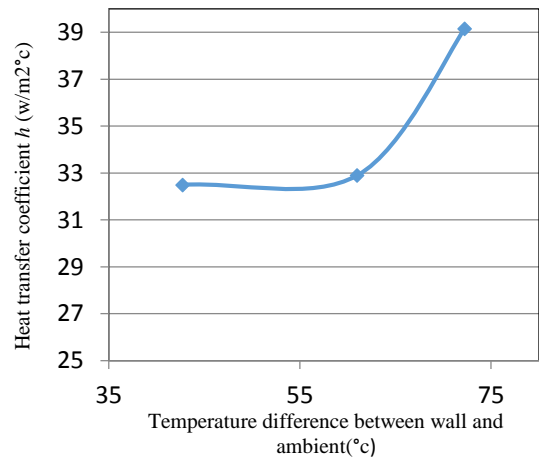

Fig. 5: Temperature difference vs. heat transfer coefficient (free convection)

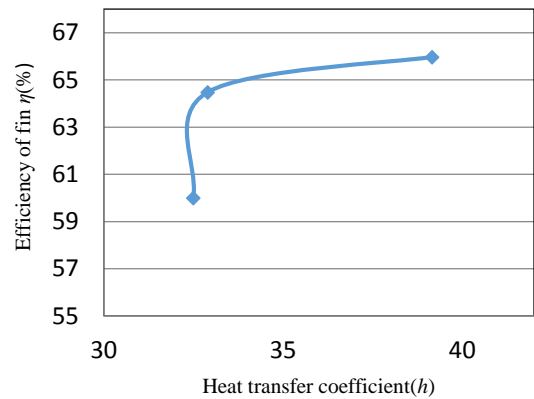

Fig. 6: Heat transfer coefficient vs. Efficiency of fin. (Free convection)

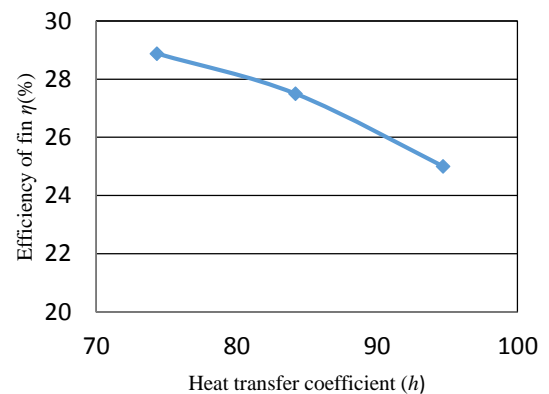

Fig. 7: Heat transfer coefficient vs. Efficiency (forced convection)

From Fig. 9, it is observed that efficiency of fin will decrease if velocity of fan is increase in force convection. From Fig. 10, it is observed that heat transfer coefficient will increase with the increase of fan velocity.

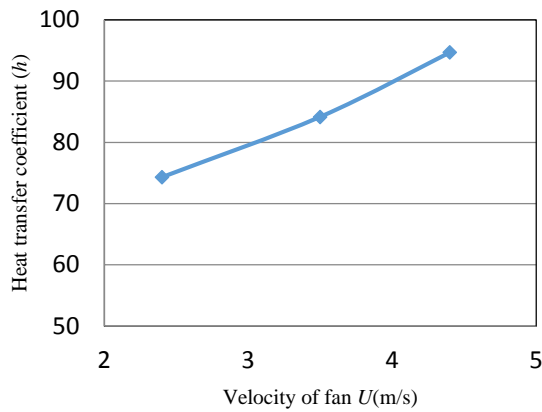

Fig. 8: Heat transfer coefficient vs. Velocity of fan (force convection)

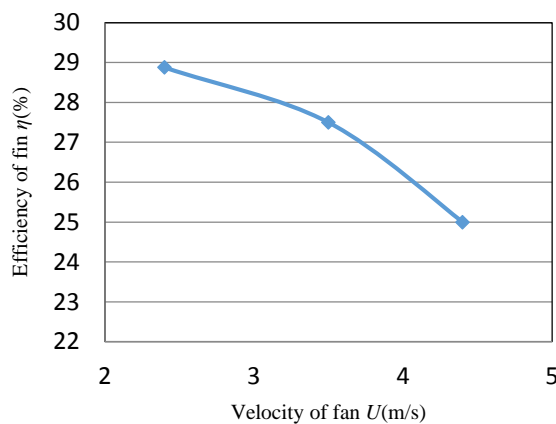

Fig. 9: Efficiency vs. velocity of fan. (Force convection)

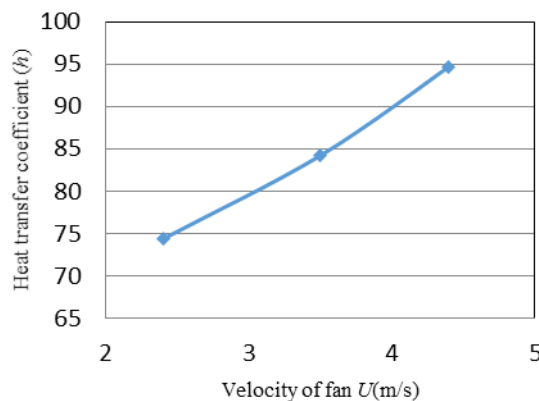

Fig. 10: Velocity vs. Heat transfer coefficient

8. CONCLUSION

Fin is used in different application for enhancing heat transfer rate. Design and fabrication of the fin may vary due to some difficulties. Avoiding air resistance between fin and plate fin must be joining smoothly with the plate wall for. To get appropriate reading, heat loss calculation and box insulation should be proper. Fin base diameter and height were kept constant in my project but there variation may affect the heat transfer coefficient. During experiment I used cylindrical heater but flat surface heater may be used for uniform heat transfer. Pin fin

array of elliptical shape may be used for future work.

9. REFERENCES

- [1] Sparrow EM, Ramsey JW. Heat transfer and pressure drop for a staggered wall-attached array of cylinders with tip clearance. *Int J Heat Mass Transfer* 1978;21:1369-77.
- [2] Sparrow EM, Ramsey JW, Altemani CAC. Experiments on in-line pin-fin arrays and performance comparison with staggered arrays. *ASME J Heat Transfer* 1980; 102:44-50.
- [3] Metzger DE, Berry RA, Bronson JP. Developing heat transfer in rectangular ducts with staggered arrays of short pin-fins. *ASME J Heat Transfer* 1982; 104:700-6.
- [4] Simoneau RJ, Vanfossen GJ. Effect of location in an array on heat transfer to a short cylinder in crossflow. *ASME J Heat Transfer* 1984; 106:42-8.
- [5] Armstrong J, Winstanley D. A review of staggered array pin-fin heat transfer for turbine cooling applications. *ASME J Turbomach* 1988; 110:94-103.
- [6] Matsumoto R, Kikkawa S, Senda M. Effect of pin-fin arrangement on end wall heat transfer. *JSME Int J* 1997; 40(Series B):142-51.
- [7] Lau, S. C., Kim, Y. S., and Han, J. C., 1985, "Effects of Fin Configuration and Entrance Length on Local End wall Heat/Mass Transfer in a Pin Fin Channel," *ASME Paper No.81-WA/HT-6*.
- [8] Damerow, W. P., Murtaugh, J. C., and Burgraf, F., 1972, "Experimental and Analytical Investigation of the Coolant Flow Characteristics in Cooled Turbine Airfoils," *NASA, CR-120883*.
- [9] Metzger, D. E., Fan, Z. N., and Shepard, W. B., 1982b, "Pressure Loss and Heat Transfer Through Multiple Rows of Short Pin Fins," *Journal of HeatTransfer*, Vol. 3, edited by U. Grigull et al., Hemisphere, Washington, pp. 137-142.
- [10] Jacob, M., 1938, "Discussion-Heat Transfer and Flow Resistance in Cross Flow of Gases Over Tube Banks," *Mech. Eng. sAm. Soc. Mech. Eng.d*, 60, pp. 381-392.
- [11] Armstrong, J. and Winstanley, D., 1988, "A Review of Staggered Array Pin Fin Heat Transfer for Turbine Cooling Applications," *ASME J. Turbomach.*, 110, pp. 94-103.
- [12] Peng, Y., 1984, "Heat Transfer and Friction Loss Characteristics of Pin Fin Cooling Configurations," *ASME J. Eng. Gas Turbines Power*, 106, pp. 246-251.
- [13] Sparrow, E. M. and Kang, S. S., 1985, "Longitudinally-finned Cross Flow Tube Banks and their Heat Transfer and Pressure Drop Characteristics," *Int. J. Heat Mass Transfer*, 28s2d, pp. 339-350.
- [14] Sparrow, E. M., Abraham, J. P., and Tong, J. C. K., 2004, "Archival Correlations for Average Heat Transfer Coefficients for Non-Circular and Circular Cylinders and for Spheres in Cross-Flow," *International Journal of Heat Mass Transfer*, 47 (24), pp. 5285-5296.
- [15] El-Sheikh, H. A., and Garimella, S. V., 2000, "Heat Transfer from Pin Fin Heat Sinks under Multiple

- Impinging Jets,” *IEEE Trans. Adv. Packag.*, 23[1], pp. 113–120.
- [16] El-Sheikh, H. A., and Garimella, S. V., 2000, “Enhancement of Air Jet Impingement Heat Transfer Using Pin Fin Heat Sinks,” *IEEE Transaction Compon. Packag. Technol.*, 23[2], pp. 300–308.
- [17] Brignoni, L. A., and Garimella, S. V., 2000, “Heat Transfer from a Finned Surface in Ducted Air Jet Suction and Impingement,” *J. Electron. Packag.*, 122, pp. 282–285.
- [18] Zukauskas, A. A., 1972, “Heat Transfer from Tubes in Cross Flow,” *Advances in Heat Transfer*, Academic, New York, Vol. 8, pp. 93–160.
- [19] Whitaker, S., 1972, “Forced Convection Heat-Transfer Correlations for Flow in Pipes, Past Flat Plates, Single Cylinders, Single Spheres, and for Flow in Packed-Beds and Tube Bundles,” *AIChE J.*, 18[2], pp. 361–371.
- [20] Igarashi, T., 1987, “Fluid Flow and Heat Transfer Around Rectangular Cylinders [the Case of a Width/Height Ratio of a Section of 0.33-1.5],” *International Journal Heat Mass Transfer*, 30, pp. 893–901.
- [21] Chyu, M. K., Hsing, Y. C., and Natarajan, V., 1998, “Convective Heat Transfer of Cubic Fin Arrays in a Narrow Channel,” *ASME J. Heat Transfer*, 120, pp. 362–367.
- [22] Merker, G. P., and Hanke, H., 1986, “Heat Transfer and Pressure Drop on the Shell-Side of Tube-Banks Having Oval-Shaped Tubes,” *International Journal Heat Mass Transfer*, 29[12], pp. 1903–1909.
- [23] Reiher, H., 1925, “Der Wärmeübergang von StrömenderLuftanRohrbündel in Kreuzstrom,” *VDI-Forschungsh.*, 269, pp. 47.
- [24] Sparrow, E. M., and Grannis, V. B., 1991, “Pressure Drop Characteristics of Heat Exchangers Consisting of Arrays of Diamond-Shaped Pin Fins,” *International Journal of Heat Mass Transfer*, 34[3], pp. 589–600.
- [25] Hilpert, R., 1933, “Der Wärmeabgabe von GeheiztenDrahten und RohrenimLuftstorm,” *Forsch. Geb.Ingenieurwes.* 4, pp. 215–224.
- [26] Ruth, E. K., 1983, “Experiments on a Cross Flow Heat Exchanger with Tubes of Lenticular Shape,” *ASME Journal of Heat Transfer*, 105, pp. 571–575.
- [27] Armstrong, J., and Winstanley, D., 1988, “A Review of Staggered Array Pin Fin Heat Transfer for Turbine Cooling Applications,” *ASME Journal Turbomach*
- [28] MizanurRahman, Design and fabrication of fin array of parabolic shape (2007) *BSc. Thesis paper*, Chittagong University of Engineering and Technology (CUET)
- [29] Sanaullah Mohammad Yusuf, Design and fabrication of fin array of rectangular shape (2007) *BSc. Thesis paper*, Chittagong University of Engineering and Technology (CUET)